

AHL5318T8 Data Sheet

Ultra Low Noise Amplifier

1. Product Overview

1.1 General Description

AHL5318T8 is a low noise amplifier with very low noise and high linearity at low dc power consumption over a single matching circuit frequency of 2.3 ~ 6.2 GHz with the minimum off-chip components. It has an active bias circuit for stable current over temperature and process variation. It also has power on/off control function. The amplifier is available in TDFN8 package and passes the stringent DC, RF and reliability tests.

1.2 Features

- Gain decreases from 18.4 dB to 17.4 dB at 3.3~3.8 GHz (18.1 dB at 3.5 GHz)
- 0.59 dB NF at 3.5 GHz
- 34.0 dBm OIP3 at 3.5 GHz
- 18.0 dBm P1dB at 3.5 GHz
- Integrated LNA on/off Control
- MTTF > 100 Years
- Single Supply: +5 V

1.3 Applications

- Low Noise Amplifier for 5G application
- Active Antenna
- Other Low Noise Application

1.4 Package Profile & RoHS Compliance

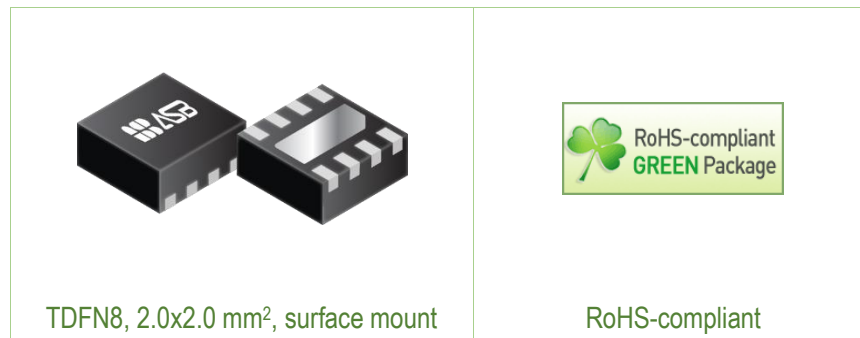

2. Summary on Product Performances

2.1 Typical Performance

Supply voltage = +5 V, T_A = +25 °C, Z₀ = 50 Ω.

Parameter	Typical								Unit
Frequency	3300	3500	3800	4500	5000	5800	6000	6200	MHz
Gain	18.4	18.1	17.4	15.8	14.9	15.1	14.6	14.0	dB
S11	-15.0	-18.0	-15.0	-15.0	-18.0	-15.0	-14.0	-11.0	dB
S22	-15.0	-15.0	-15.0	-12.0	-13.0	-13.0	-13.0	-10.0	dB
Noise Figure ¹⁾	0.58	0.59	0.60	0.80	0.90	1.05	1.10	1.15	dB
Output IP3 ²⁾	34.0	34.0	35.0	35.0	34.0	33.0	32.0	31.0	dBm
Output P1dB	18.0	18.0	18.0	17.0	17.0	17.0	16.0	15.0	dBm
Current	65								mA
Device Voltage	5								V

1) Noise figure measured at the connectors on the board. (i.e. not de-embedded)

2) OIP3 is measured with two tones at the output power of +4 dBm/tone separated by 1 MHz.

Parameter	Conditions	Min	Typ	Max	Unit
Power Shutdown Control (V _c)	On state		0		V
	Off state		1.0		V
Current	On state		65		mA
	Off state		3		mA
Switching Speed	Rise time (10% to 90%)		150		ns
	Fall time (90% to 10%)		150		ns

2.2 Product Specification

Supply voltage = +5 V, T_A = +25 °C, Z₀ = 50 Ω.

Parameter	Min	Typ	Max	Unit
Frequency		3500		MHz
Noise Figure		0.59		dB
Gain		18.1		dB
S11		-18.0		dB
S22		-15.0		dB
Output IP3		34.0		dBm
Output P1dB		18.0		dBm
Current		65		mA
Device Voltage		+5		V

2.3 Pin Configuration

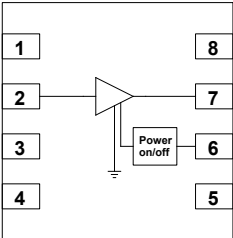
Pin	Description	Simplified Outline
2	RF IN	
6	Vc (on/off function)	
7	RF OUT	
1, 3, 4, 5, 8	NC or GND	
Backside paddle	GND	

2.4 Absolute Maximum Ratings

Parameters	Max. Ratings
Operation Case Temperature	-40 to +105 °C
Storage Temperature	-40 to +150 °C
Device Voltage	+6 V
Operation Junction Temperature	+150 °C
Input RF Power (CW, 50 Ω matched)	TBD

2.5 Thermal Resistance

Symbol	Description	Typ	Unit
R _{th}	Thermal resistance from junction to lead	90	°C/W

2.6 ESD Classification & Moisture Sensitivity Level

ESD Classification

HBM	TBD
-----	-----

CAUTION: Gallium Arsenide Integrated Circuits are sensitive to electrostatic discharge (ESD) and can be damaged by static electricity. Proper ESD control techniques should be used when handling these devices.

Moisture Sensitivity Level

MSL 3 at 260 °C reflow

(Intentionally Blanked)

3. Application: 3300~3800 MHz ($V_{\text{DEVICE}} = +5 \text{ V}$)

3.1 Application Circuit & Evaluation Board

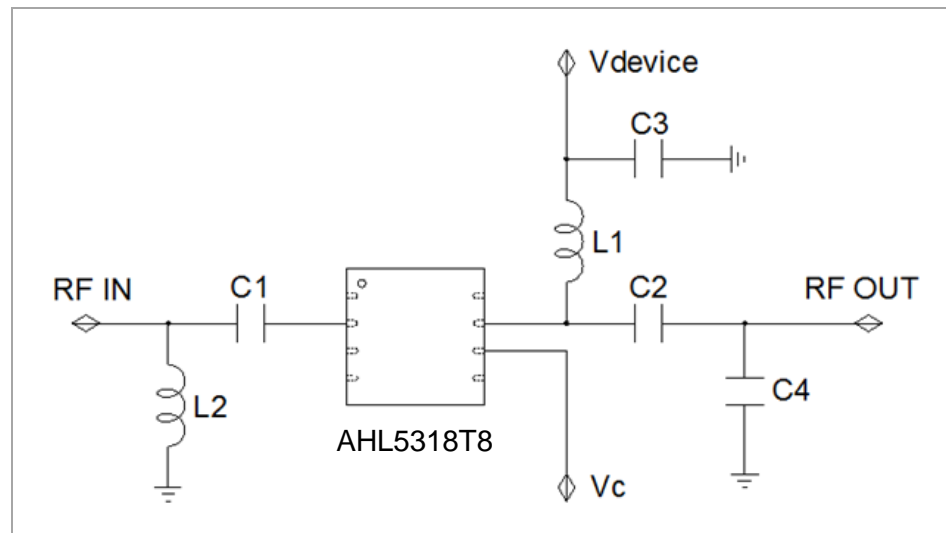

* Backside paddle is RF/ DC ground.

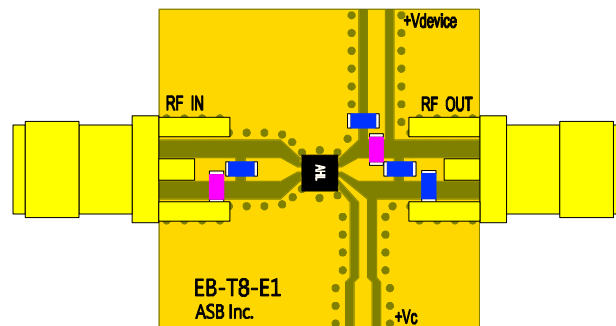

State	Vc (V)
LNA ON	0 or GND
OFF	1.0 ~ Vd

PCB Information	
Material	FR4
Thickness (mm)	0.8
Size (mm)	18x18
EB No.	EB-T8-E1

Bill of Material

Symbol	Value	Size	Description	Manufacturer
AHL5318T8	-	-	MMIC amplifier	ASB
C1	1 pF	0603	DC blocking capacitor	Murata
C2	22 pF	0603	DC blocking capacitor	Murata
C3	1 μ F	0603	Decoupling capacitor	Murata
C4	0.3 pF	0603	Output matching capacitor	Murata
L1	2.7 nH	0603	RF choke inductor	Murata
L2	2.7 nH	0603	Input matching inductor	Murata

3.2 Performance Table

Supply voltage = +5 V, $T_A = +25\text{ }^\circ\text{C}$, $Z_0 = 50\ \Omega$.

Parameter	Typical			Unit
Frequency	3300	3500	3800	MHz
Gain	18.4	18.1	17.4	dB
S11	-15.0	-18.0	-15.0	dB
S22	-15.0	-15.0	-15.0	dB
Noise Figure ¹⁾	0.58	0.59	0.60	dB
Output IP3 ²⁾	34.0	34.0	35.0	dBm
Output P1dB	18.0	18.0	18.0	dBm
Current	65			mA
Device Voltage	5			V

1) Noise figure measured at the connectors on the board. (i.e. not de-embedded)

2) OIP3 is measured with two tones at the output power of +4 dBm/tone separated by 1 MHz.

3.3 Plot of S-parameters

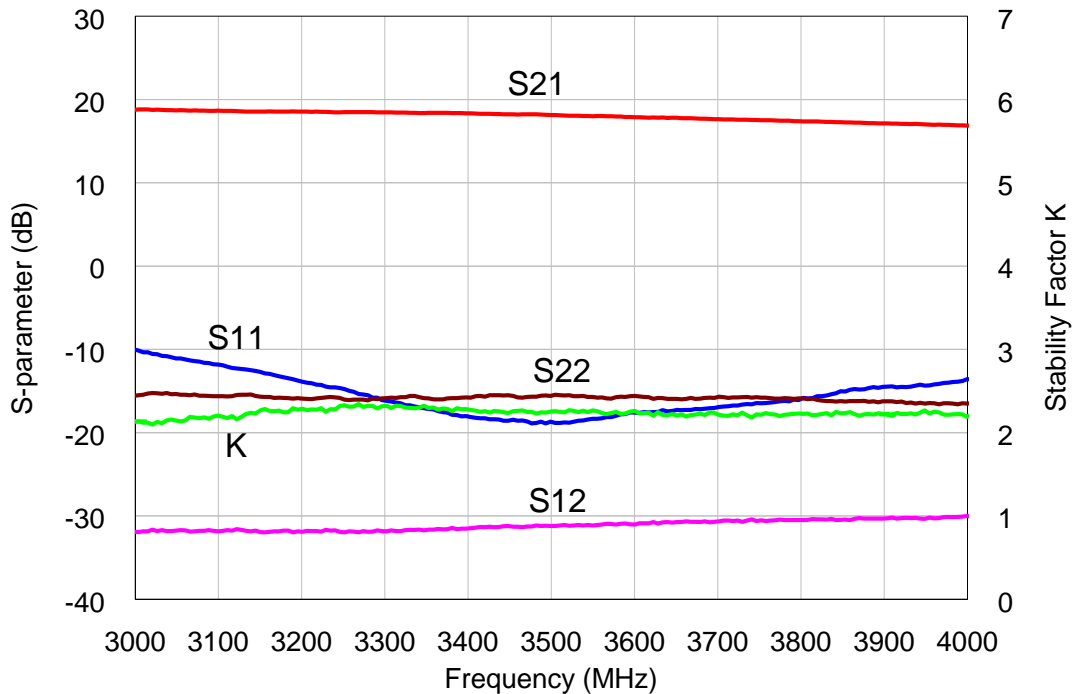

3.4 Plots of Noise Figure and Performances with Temperature

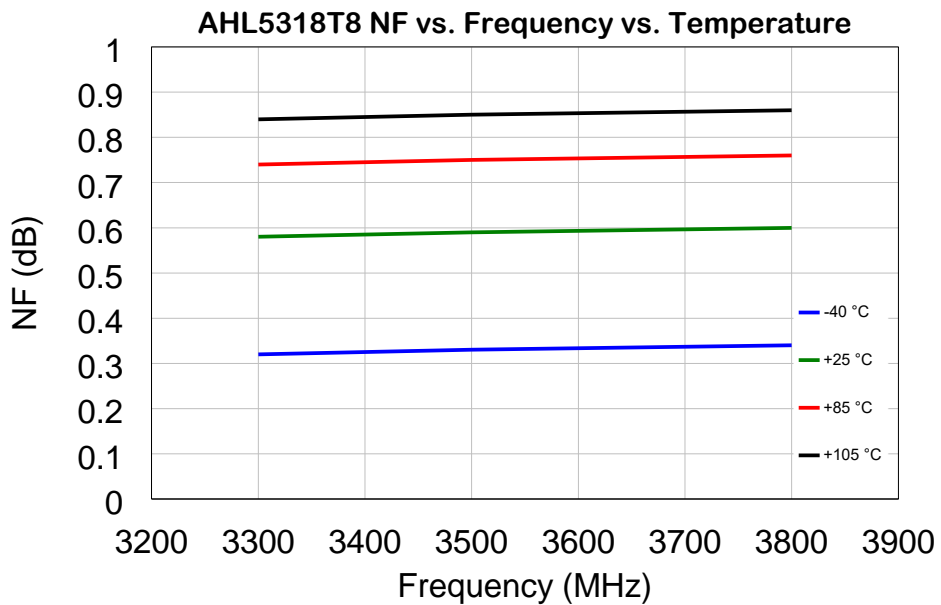
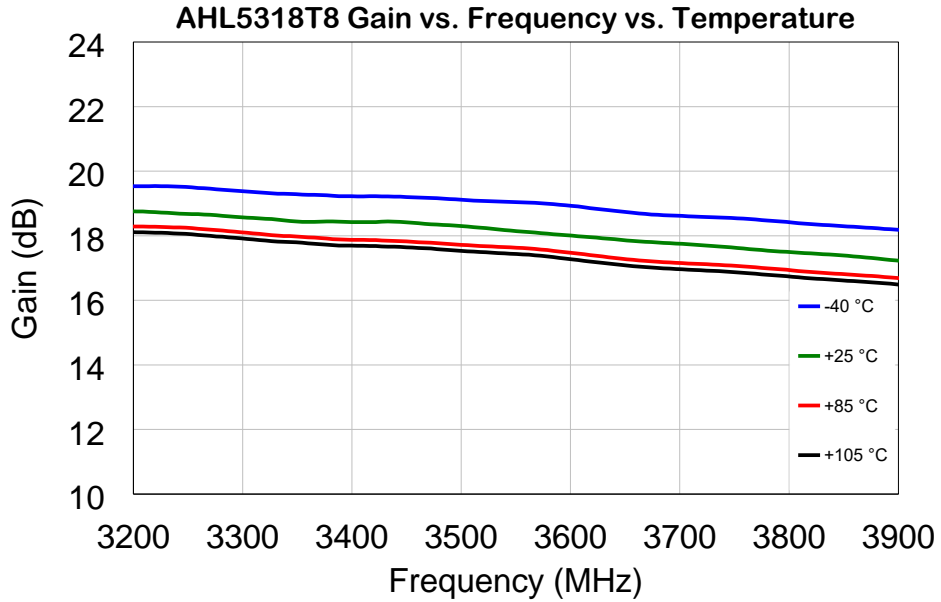

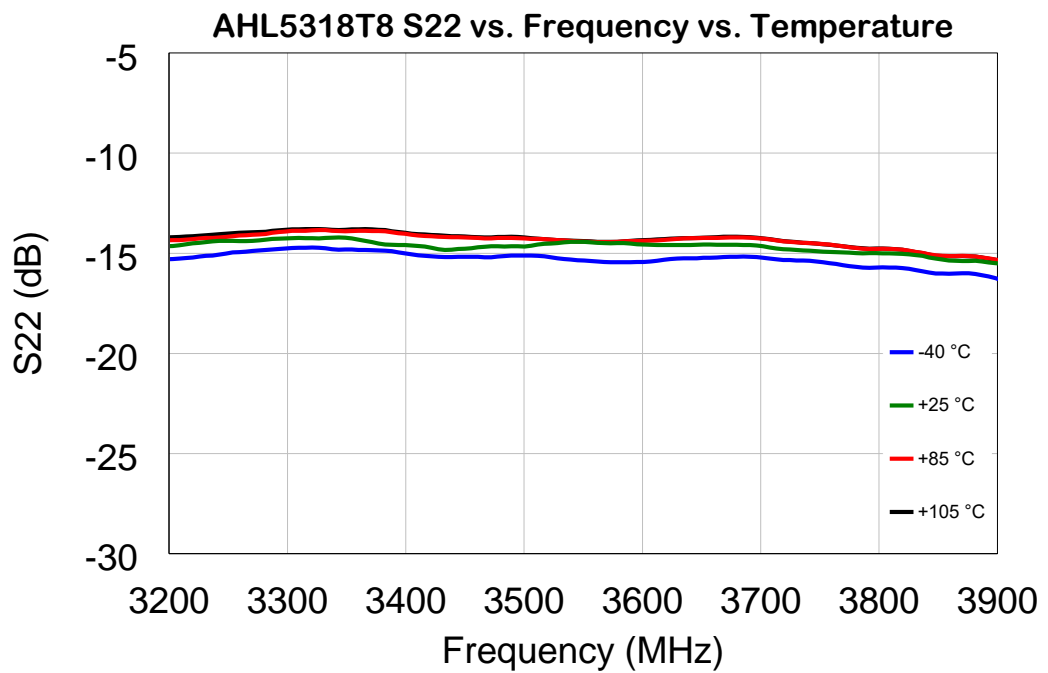
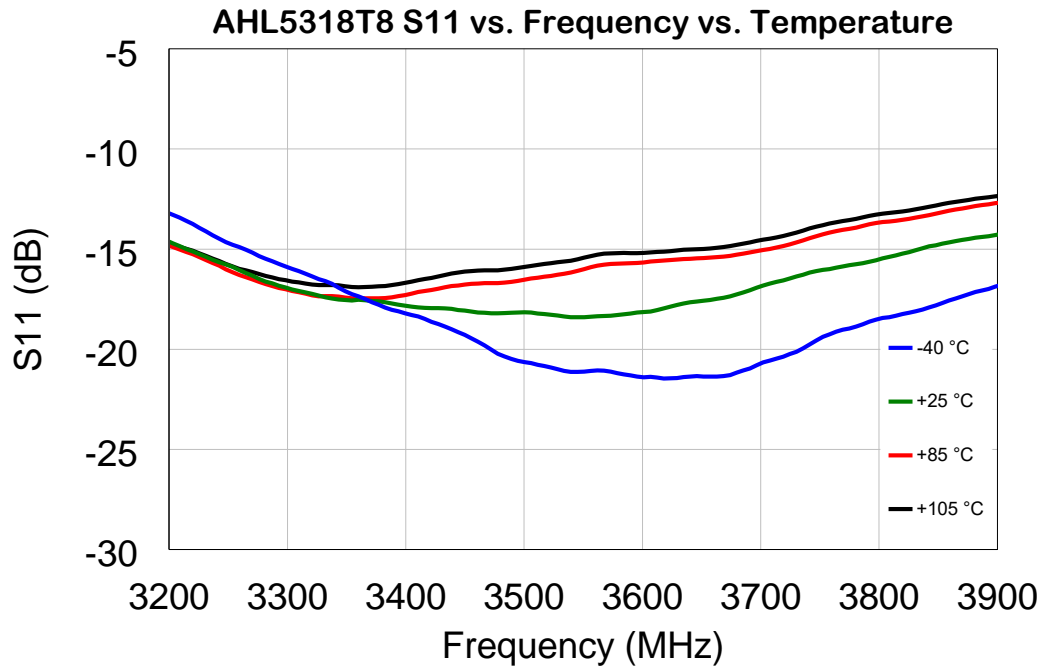

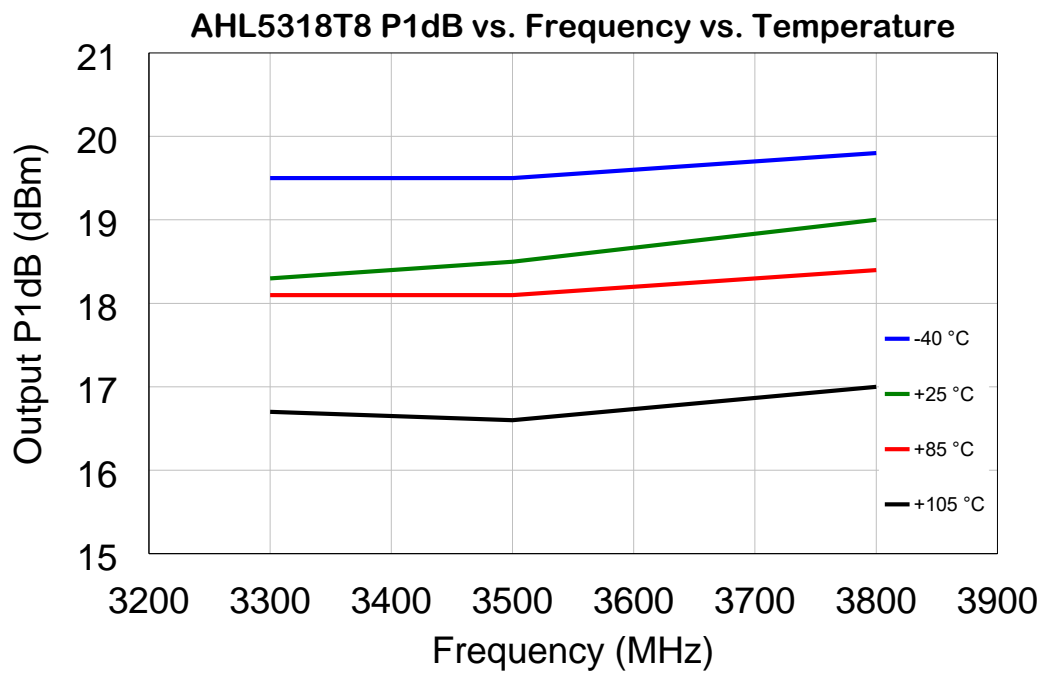
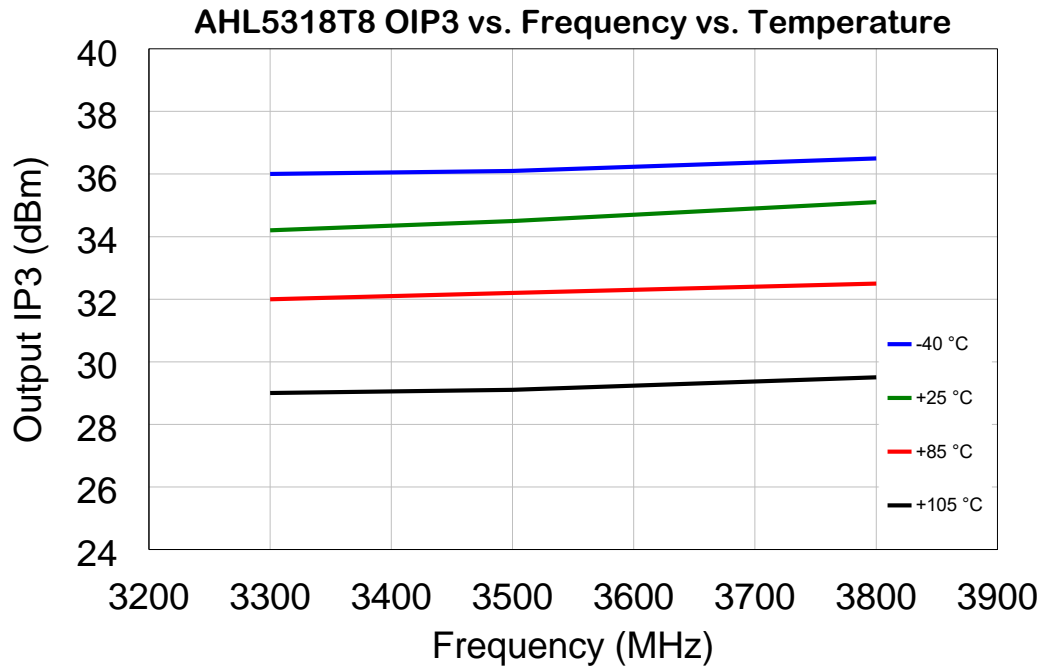

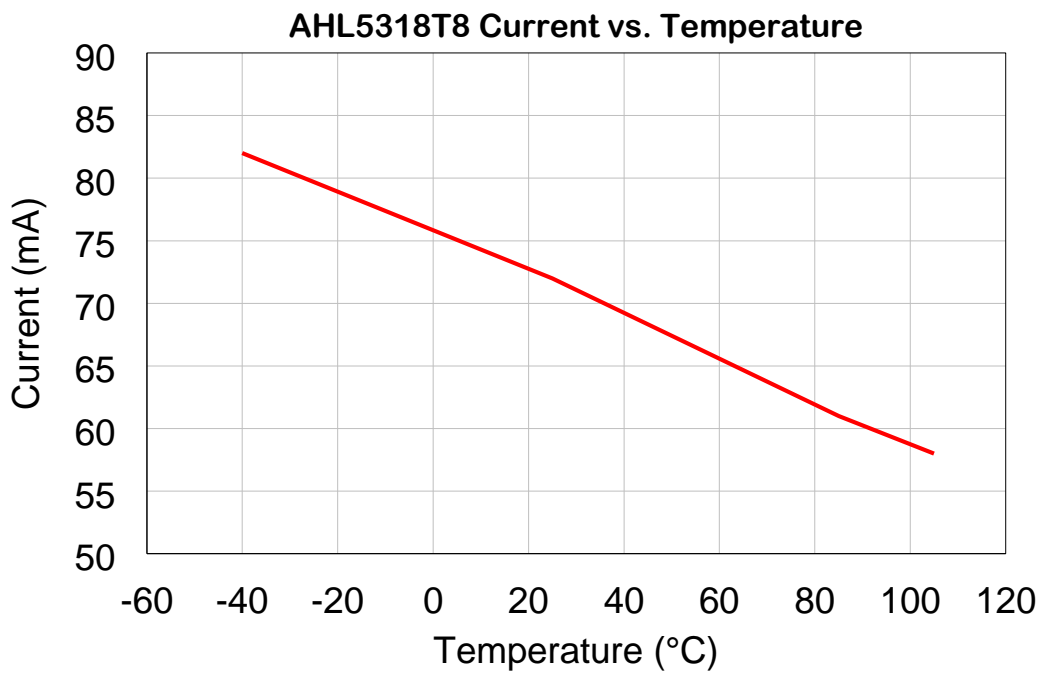
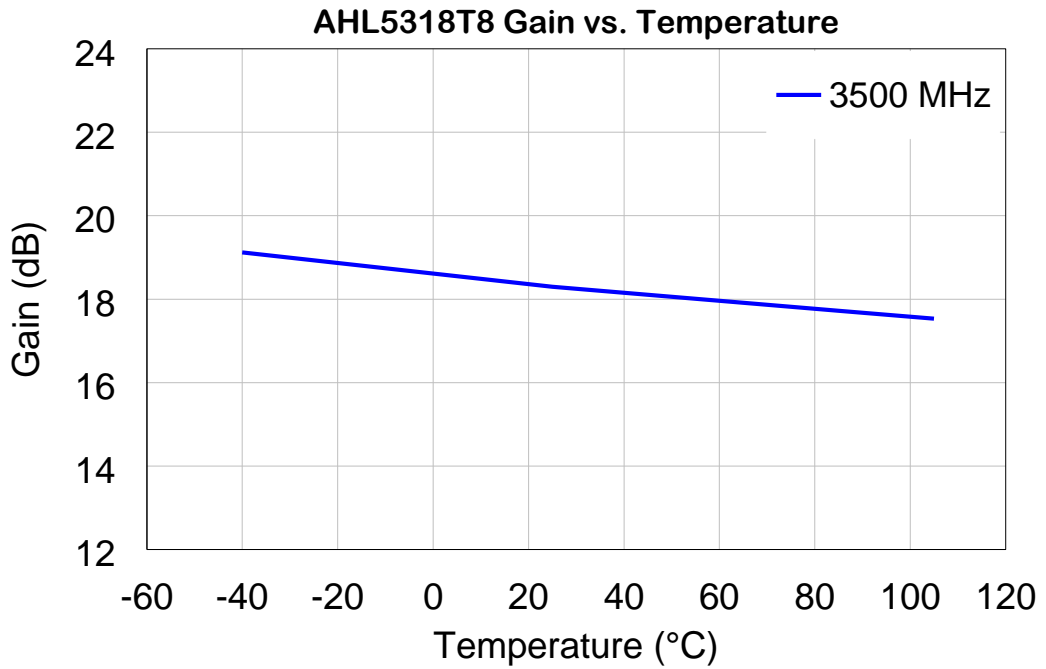

4. Application: 4500~5000 MHz ($V_{\text{DEVICE}} = +5 \text{ V}$)

4.1 Application Circuit & Evaluation Board

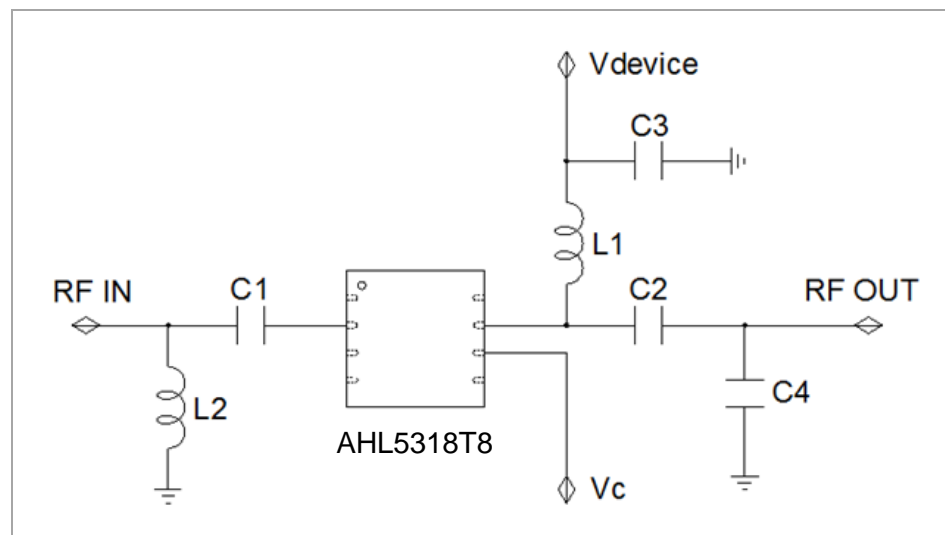

* Backside paddle is RF/ DC ground.

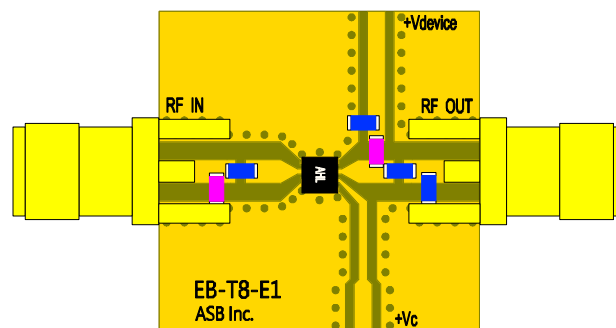

State	Vc (V)
LNA ON	0 or GND
OFF	1.0 ~ Vd

PCB Information	
Material	FR4
Thickness (mm)	0.8
Size (mm)	18x18
EB No.	EB-T8-E1

Bill of Material

Symbol	Value	Size	Description	Manufacturer
AHL5318T8	-	-	MMIC amplifier	ASB
C1	0.5 pF	0603	DC blocking capacitor	Murata
C2	22 pF	0603	DC blocking capacitor	Murata
C3	1 μ F	0603	Decoupling capacitor	Murata
C4	0.3 pF	0603	Output matching capacitor	Murata
L1	2.7 nH	0603	RF choke inductor	Murata
L2	2.2 nH	0603	Input matching inductor	Murata

4.2 Performance Table

Supply voltage = +5 V, $T_A = +25\text{ }^\circ\text{C}$, $Z_0 = 50\ \Omega$.

Parameter	Typical			Unit
Frequency	4500	4700	5000	MHz
Gain	15.8	15.4	14.9	dB
S11	-15.0	-18.0	-18.0	dB
S22	-12.0	-13.0	-13.0	dB
Noise Figure ¹⁾	0.80	0.85	0.90	dB
Output IP3 ²⁾	35.0	35.0	34.0	dBm
Output P1dB	17.0	17.0	17.0	dBm
Current	65			mA
Device Voltage	5			V

1) Noise figure measured at the connectors on the board. (i.e. not de-embedded)

2) OIP3 is measured with two tones at the output power of +4 dBm/tone separated by 1 MHz.

4.3 Plot of S-parameters & Noise Figure

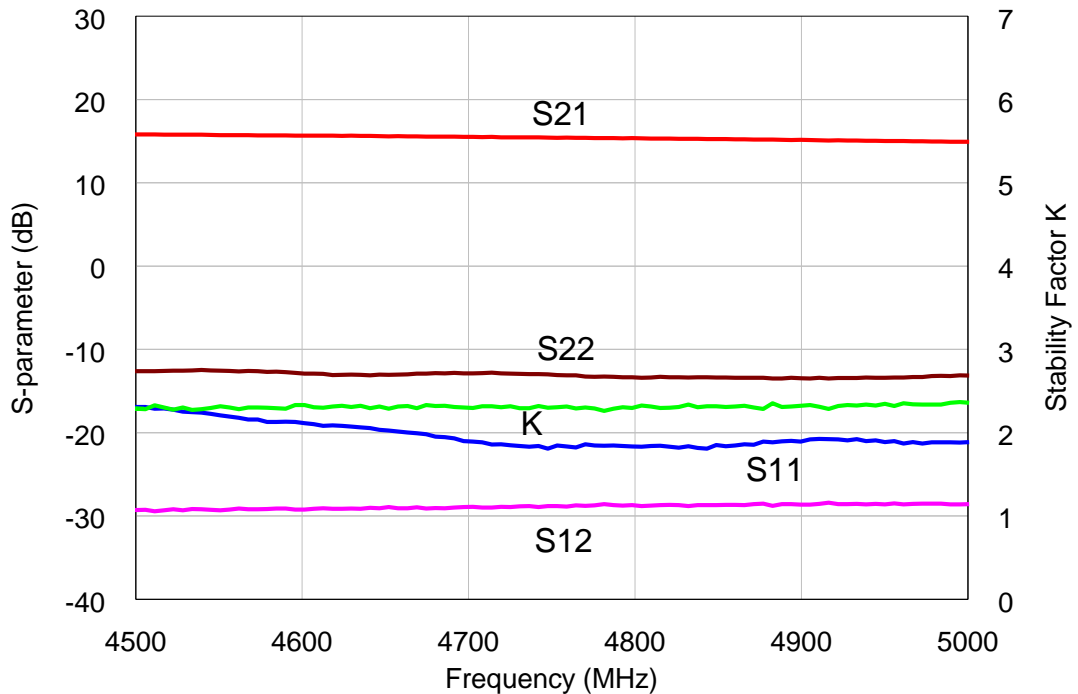

5. Application: 5600~6200 MHz ($V_{\text{DEVICE}} = +5 \text{ V}$)

5.1 Application Circuit & Evaluation Board

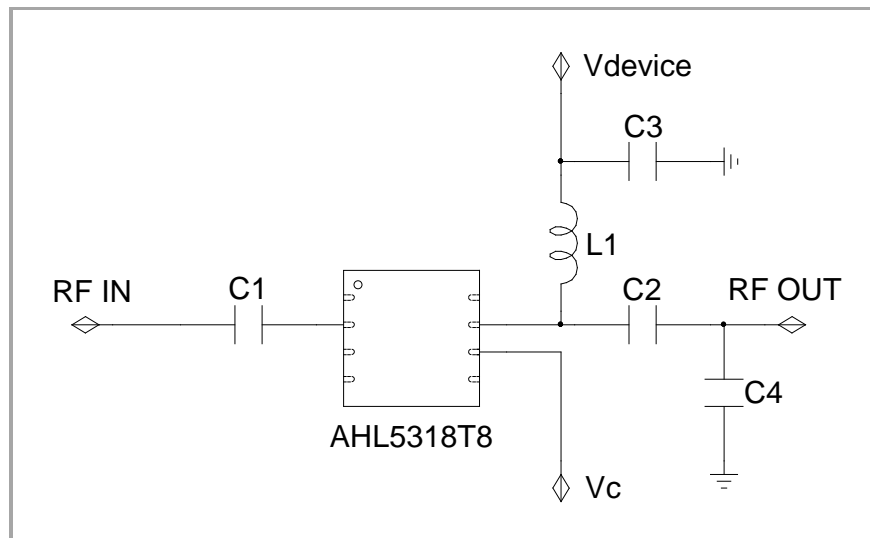

* Backside paddle is RF/ DC ground.

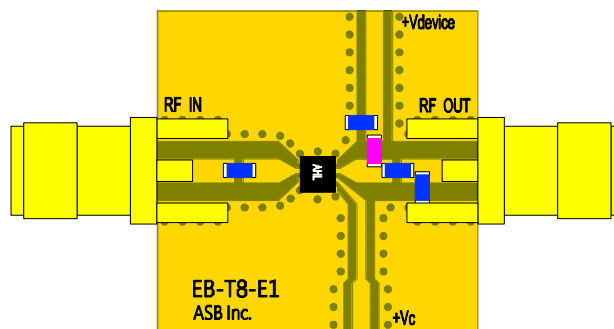

State	Vc (V)
LNA ON	0 or GND
OFF	1.0 ~ Vd

PCB Information	
Material	FR4
Thickness (mm)	0.8
Size (mm)	18x18
EB No.	EB-T8-E1

Bill of Material

Symbol	Value	Size	Description	Manufacturer
AHL5318T8	-	-	MMIC amplifier	ASB
C1	0.75 pF	0603	DC blocking capacitor	Murata
C2	1 pF	0603	DC blocking capacitor	Murata
C3	1 μ F	0603	Decoupling capacitor	Murata
C4	0.3 pF	0603	Output matching capacitor	Murata
L1	2.7 nH	0603	RF choke inductor	Murata

5.2 Performance Table

Supply voltage = +5 V, T_A = +25 °C, Z₀ = 50 Ω.

Parameter	Typical				Unit
Frequency	5600	5800	6000	6200	MHz
Gain	15.3	15.1	14.6	14.0	dB
S11	-14.0	-15.0	-14.0	-11.0	dB
S22	-10.0	-13.0	-13.0	-10.0	dB
Noise Figure ¹⁾	1.10	1.05	1.10	1.15	dB
Output IP3 ²⁾	33.0	33.0	32.0	31.0	dBm
Output P1dB	17.0	17.0	16.0	15.0	dBm
Current	65				mA
Device Voltage	5				V

1) Noise figure measured at the connectors on the board. (i.e. not de-embedded)

2) OIP3 is measured with two tones at the output power of +4 dBm/tone separated by 1 MHz.

5.3 Plot of S-parameters & Noise Figure

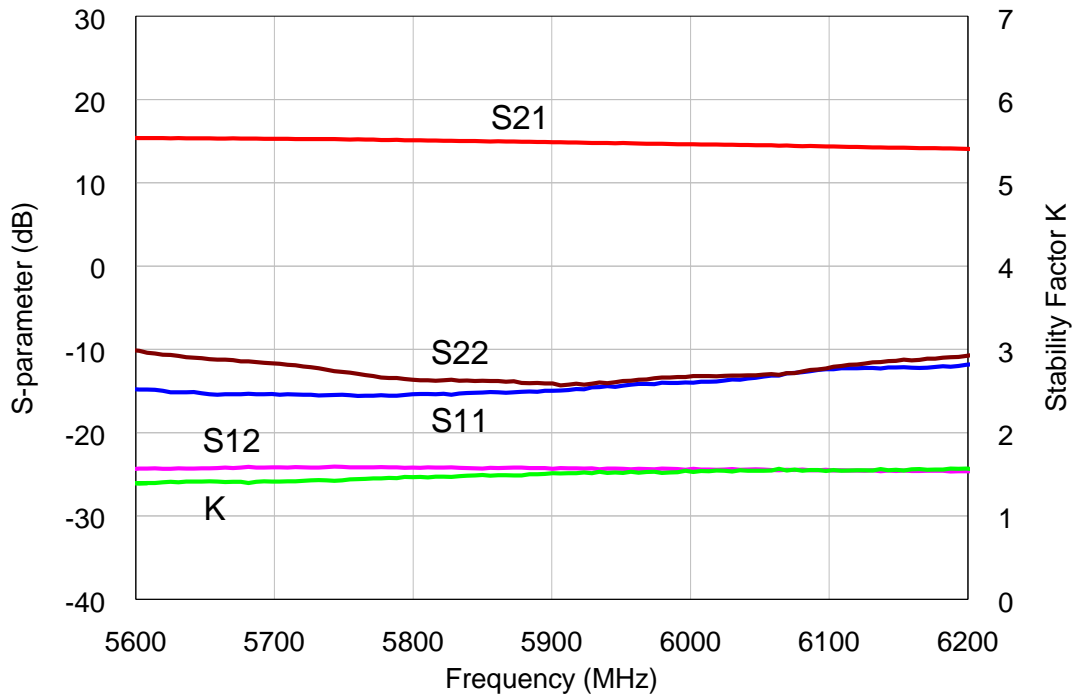

6. Application: 2300~2700 MHz ($V_{\text{DEVICE}} = +5 \text{ V}$)

6.1 Application Circuit & Evaluation Board

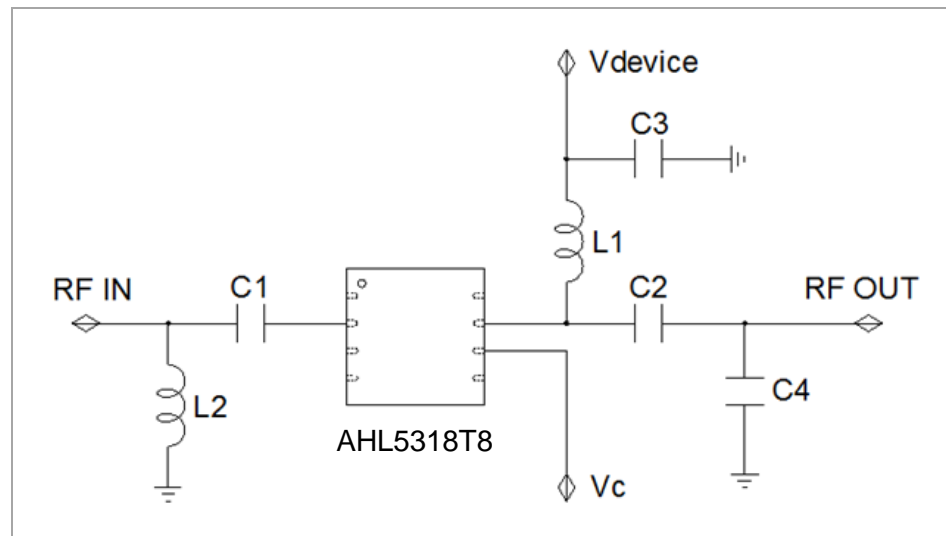

* Backside paddle is RF/ DC ground.

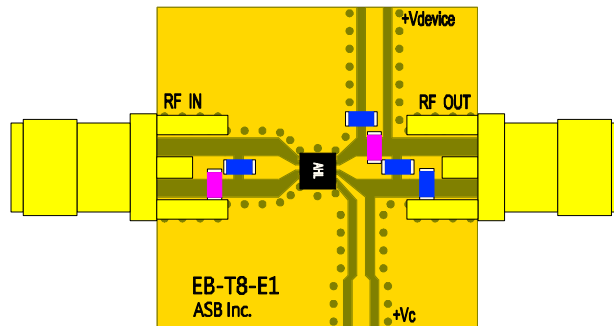

State	Vc (V)
LNA ON	0 or GND
OFF	1.0 ~ Vd

PCB Information	
Material	FR4
Thickness (mm)	0.8
Size (mm)	18x18
EB No.	EB-T8-E1

Bill of Material

Symbol	Value	Size	Description	Manufacturer
AHL5318T8	-	-	MMIC amplifier	ASB
C1	2.4 pF	0603	DC blocking capacitor	Murata
C2	22 pF	0603	DC blocking capacitor	Murata
C3	1 μ F	0603	Decoupling capacitor	Murata
C4	0.5 pF	0603	Output matching capacitor	Murata
L1	2.2 nH	0603	RF choke inductor	Murata
L2	2.7 nH	0603	Input matching inductor	Murata

6.2 Performance Table

Supply voltage = +5 V, T_A = +25 °C, Z₀ = 50 Ω.

Parameter	Typical			Unit
Frequency	2300	2500	2700	MHz
Gain	21.4	21.1	20.2	dB
S11	-14.0	-18.0	-16.0	dB
S22	-12.0	-15.0	-18.0	dB
Noise Figure ¹⁾	0.58	0.52	0.53	dB
Output IP3 ²⁾	31.0	32.0	33.0	dBm
Output P1dB	19.0	19.0	20.0	dBm
Current	65			mA
Device Voltage	5			V

1) Noise figure measured at the connectors on the board. (i.e. not de-embedded)

2) OIP3 is measured with two tones at the output power of +4 dBm/tone separated by 1 MHz.

6.3 Plot of S-parameters & Noise Figure

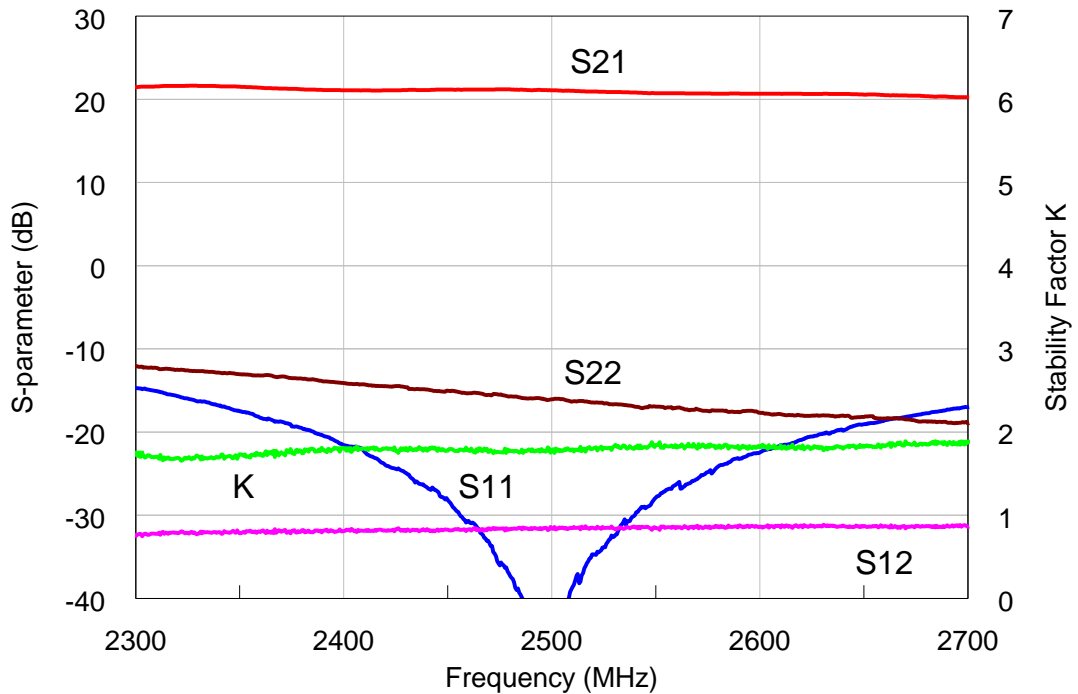

7. Application: 600~5000 MHz ($V_{\text{DEVICE}} = +5 \text{ V}$)

7.1 Application Circuit & Evaluation Board

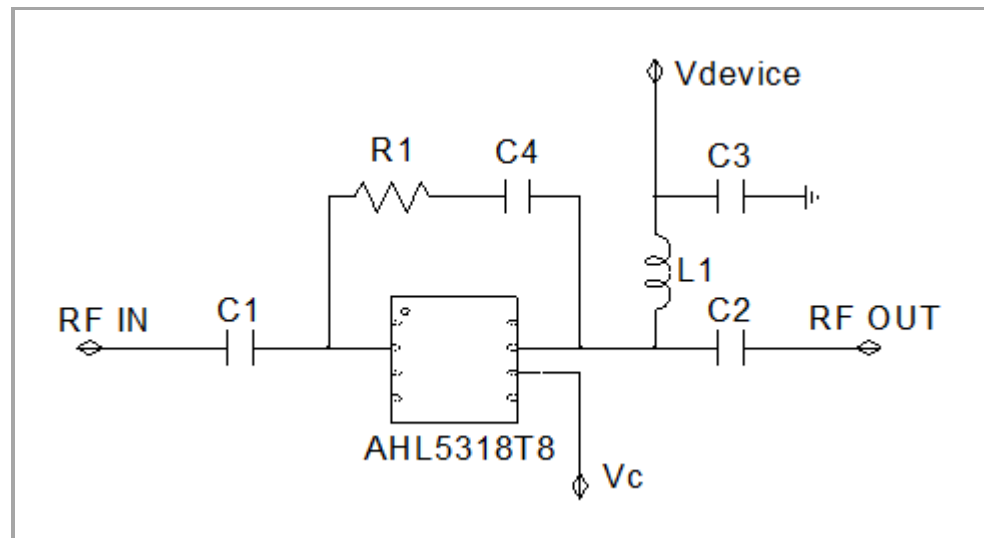

* Backside paddle is RF/ DC ground.

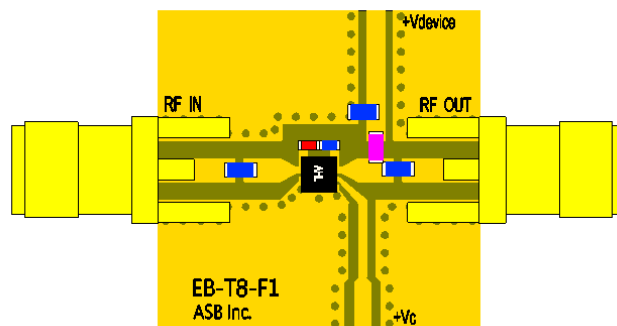

State	Vc (V)
LNA ON	0 or GND
OFF	1.0 ~ Vd

PCB Information	
Material	FR4
Thickness (mm)	0.8
Size (mm)	18x18
EB No.	EB-T8-F1

Bill of Material

Symbol	Value	Size	Description	Manufacturer
AHL5318T8	-	-	MMIC amplifier	ASB
C1	100 pF	0603	DC blocking capacitor	Murata
C2	100 pF	0603	DC blocking capacitor	Murata
C3	1 μ F	0603	Decoupling capacitor	Murata
C4	100 pF	0603	Feedback capacitor	Murata
L1	68 nH	0603	RF choke inductor	Murata
R1	820 ohm	0603	Feedback resistor	Samsung

7.2 Performance Table

Supply voltage = +5 V, $T_A = +25\text{ }^\circ\text{C}$, $Z_0 = 50\ \Omega$.

Parameter	Typical				Unit
Frequency	600	2000	3500	5000	MHz
Gain	23.5	19.0	15.9	14.1	dB
S11	-18.0	-18.0	-18.0	-16.0	dB
S22	-12.0	-18.0	-18.0	-12.0	dB
Noise Figure ¹⁾	0.65	0.80	1.00	1.30	dB
Output IP3 ²⁾	34.0	33.5	33.0	32.0	dBm
Output P1dB	19.0	19.0	18.0	17.0	dBm
Current	65				mA
Device Voltage	5				V

1) Noise figure measured at the connectors on the board. (i.e. not de-embedded)

2) OIP3 is measured with two tones at the output power of +4 dBm/tone separated by 1 MHz.

7.3 Plot of S-parameters & Noise Figure

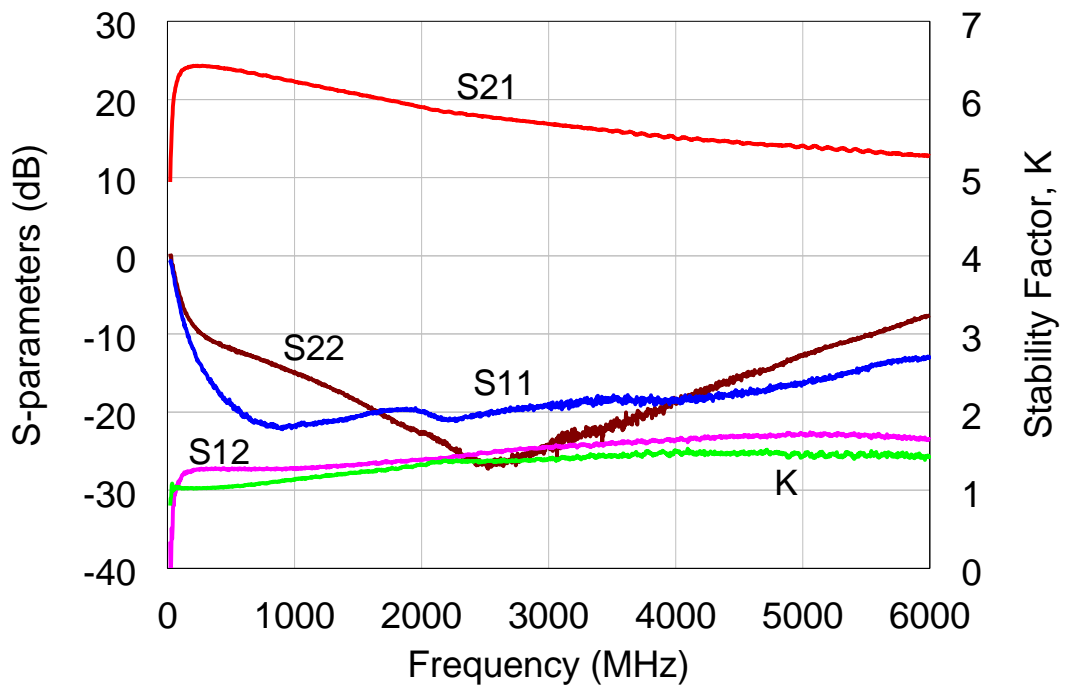

8. Package Outline (TDFN8)

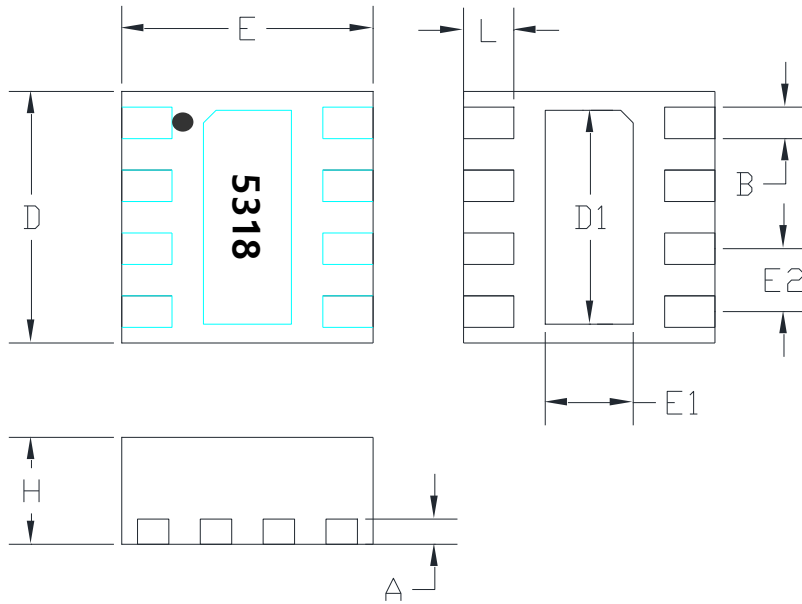

Symbols	Dimensions (In mm)		
	MIN	NOM	MAX
A	-	0.20REF	-
B	0.18	0.23	0.28
D	1.95	2.00	2.03
D1	-	1.7BSC	-
E	1.95	2.00	2.03
E1	-	0.7BSC	-
E2	-	0.5BSC	-
L	0.35	0.40	0.45
H	0.80	0.85	0.90

9. Surface Mount Recommendation (In mm)

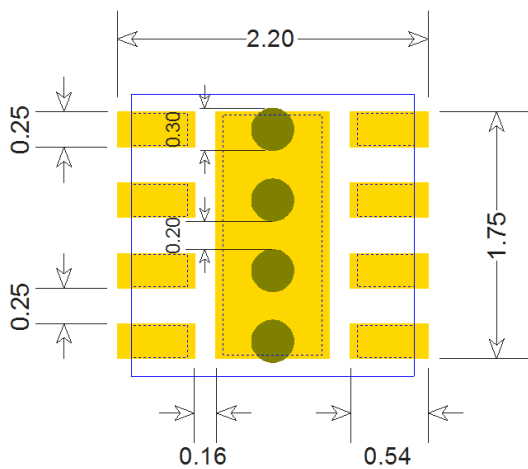

NOTE

1. The number and size of ground via holes in a circuit board is critical for thermal and RF grounding considerations.
2. Recommend is that the ground via holes be placed on the bottom of exposed pad of the device for better RF and thermal performance, as shown in the drawing at the left side.

10. Recommended Soldering Reflow Profile

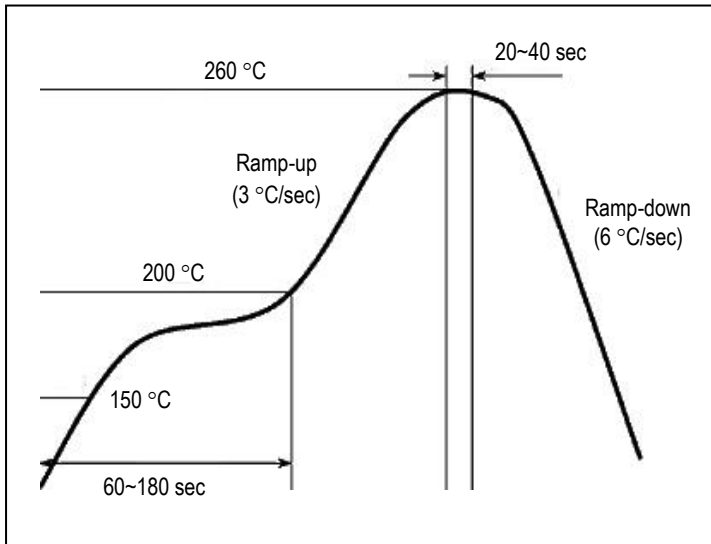

(End of Datasheet)

Copyright © 2020~2021 ASB Inc. All rights reserved. Specifications subject to change without notice. ASB assumes no responsibility for any errors which may appear in this datasheet. No part of the datasheet may be copied or reproduced in any form or by any means without the prior written consent of ASB.